

MEMORANDUM

TO: City Council

FROM: John L. Fitzwater
Acting City Manager

SUBJECT: *Status Report*

DATE: June 23, 2016

Status Report

1. WSSC Water Main Improvement Project

WSSC will be hosting a public meeting at the South Bowie Community Center on June 30, 2016 from 7:00-8:30 p.m. to provide information about their upcoming water main replacement project in the Pointer Ridge community. Most of this project will be in the vicinity of Peach Walker Drive and adjoining streets. Construction is expected to begin in Spring 2017 and be completed by Spring 2019. A copy of the letter sent to affected residents is attached. The meeting was announced in the June 2016 Bowie News Flash. Meeting information will also be distributed to affected areas through an Alert Bowie message and Robo call on Monday, June 27.

2. Speed Traffic Trailer Placement for July

Public Works will be placing the speed traffic trailer on the following streets in July: Orchard Run Drive, Atlantis Drive, Memphis Lane, Peach Walker Drive, Triple Crown Road, Holiday Lane, Pleasant View Drive, Driftwood Road, Idlewild Drive, Arbor Hill Lane, Buckingham Drive, Elder Oaks Blvd., Kavanaugh Lane and Pennsbury Drive. Trailer is left for several days at each location.

3. Installation of Radio Read Water Meters

The FY17 budget allocates funds for the installation of replacement radio read water meters. The Public Works Department has identified a contract through St. Mary's County, #WO1112, with National Metering Services, LLC to provide this service for \$48,262.20, which is within the \$48,300 budget. The meters will be purchased under a separate Council authorization.

Installation of the meters will not begin until after July 1, 2016. As provided by Section 62 of the City Charter, this will serve as the required seven-day notice of intent to enter into an agreement with National Metering Services, LLC for a total amount of \$48,262.20.

4. Melford Boulevard Changes

St. Johns properties will be meeting with Bowie Public Works and Maryland State Highway Administration (SHA) on June 28 to discuss the pending project to modify Belair Drive and Melford Boulevard between Kendale Lane to the west and Science Drive to the east. The improvements are related to required conditions of the Conceptual Site Plan approval for a pedestrian connection at this location.

The improvements include:

- 1) A sidewalk will be added on the south side of Belair Drive from Kendale Lane, extending under the MD Route 3 overpass and joining the sidewalk along Melford Blvd. at the Science Drive intersection.
- 2) The SHA maintained intersection at the ramp from MD 3 to Melford Blvd. will be modified to eliminate the high speed ramp. All traffic will travel through the signalized intersection. This eliminates what would be a dangerous pedestrian crossing across the high speed ramp.
- 3) The current traffic roundabout at Melford Blvd. and Science Drive will be replaced with a signalized intersection. The roundabout is not suitable for the future traffic estimates at this intersection. The signalized intersection will adequately meet requirements to the anticipated traffic volume and will improve pedestrian safety.

The purpose of the meeting is to communicate any unique design requirements that the City or the State may have. St. John's is seeking to begin design in the immediate future with a goal of construction in Spring of 2017.

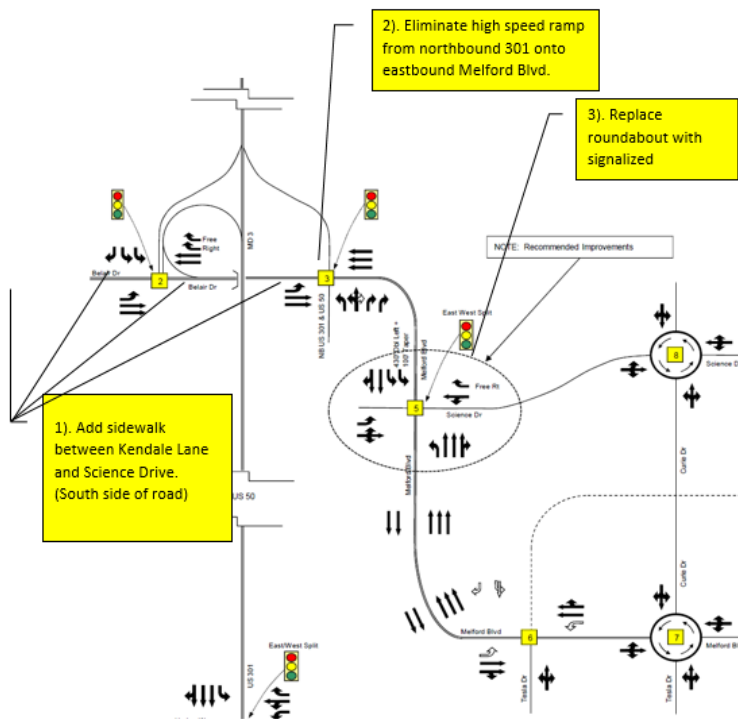



City Court
65
D/E
C/F
RECEIVED
JUN 14 2016
Bowie City Clerk's Office

June 9, 2016

MR. G. FREDERICK ROBINSON
MAYOR, CITY OF BOWIE
15901 EXCALIBUR ROAD
BOWIE, MD 20716

RE: Mitchellville South Park Water Main Replacement Project

The Washington Suburban Sanitary Commission (WSSC) plans to replace approximately 3.26 miles of water mains and service connections in your area. Construction is expected to begin in spring 2017 and be completed by spring 2019, weather permitting.

For your convenience, you will find a project map on the back of this letter. The affected streets include: **Peach Walker Drive, Pennfield Lane, Penn Place, Pecan Lane, Passaie Lane, Plumwood Court, Powell Lane, Puritan Place, Paris Court, Page Court, Plymouth Court, Perkins Lane, Pacific Court, Packer Court, Palai Turn, Pomona Place, Piller Lane, Perrell Lane, and Paisley Lane.**

This project is necessary because the water mains are nearing the end of their life cycle. Providing a reliable supply of safe drinking water continues to be our highest priority. However, after nearly a century of service, WSSC is facing the same problem confronting water providers across the country – a decaying infrastructure. The water mains within the project area were originally installed in the 1960's - 1970's. These mains will be replaced with new ductile iron pipe which will greatly reduce the frequency of water main breaks, while providing the same high-quality water that WSSC has always provided its customers.

In the event your water service line is galvanized pipe, WSSC will replace the portion of the water main between the public main and the property line connection, at no cost to you. Please note that some trees may have to be pruned or removed to accommodate the work. Residents will be notified ahead of time, if there is a need for any tree removal.

All work is expected to be conducted weekdays from 9:00 a.m. to 4:00 p.m. WSSC will work closely with the residents and regulatory agencies to minimize disruptions to traffic and the environment. Water service may be interrupted while the new main is being connected into the existing main, however this will be limited to a few hours at a time. Residents will receive more detailed information prior to any scheduled service interruption.

To receive an e-mail or text message alert when your water service is disrupted, you may register for WSSC's Customer Notification System (CNS). Visit WSSC's home page at www.wsscwater.com on the right-hand side, under "Quick Links" to sign up. The service is FREE but standard text messaging rates may apply.

If you have any questions about this project or need additional information, please contact me at 301-206-7946 or by e-mail at bhusan.basnet@wsscwater.com and refer to Project No. BR5971A15. However, if you experience a water or sewer emergency, please contact our **24-Hour Emergency Call Center** at [301-206-4002](tel:301-206-4002). You may click on the following link to find out more about WSSC projects in your neighborhood: <https://gis.wsscwater.com/inyourneighborhood>.

Sincerely,

Bhusan Basnet
Project Manager - Infrastructure Systems Group

Washington Suburban Sanitary Commission

MITCHELLVILLE SOUTH PARK WATER MAIN REPLACEMENT WSSC CONTRACT NO. BR5971A15

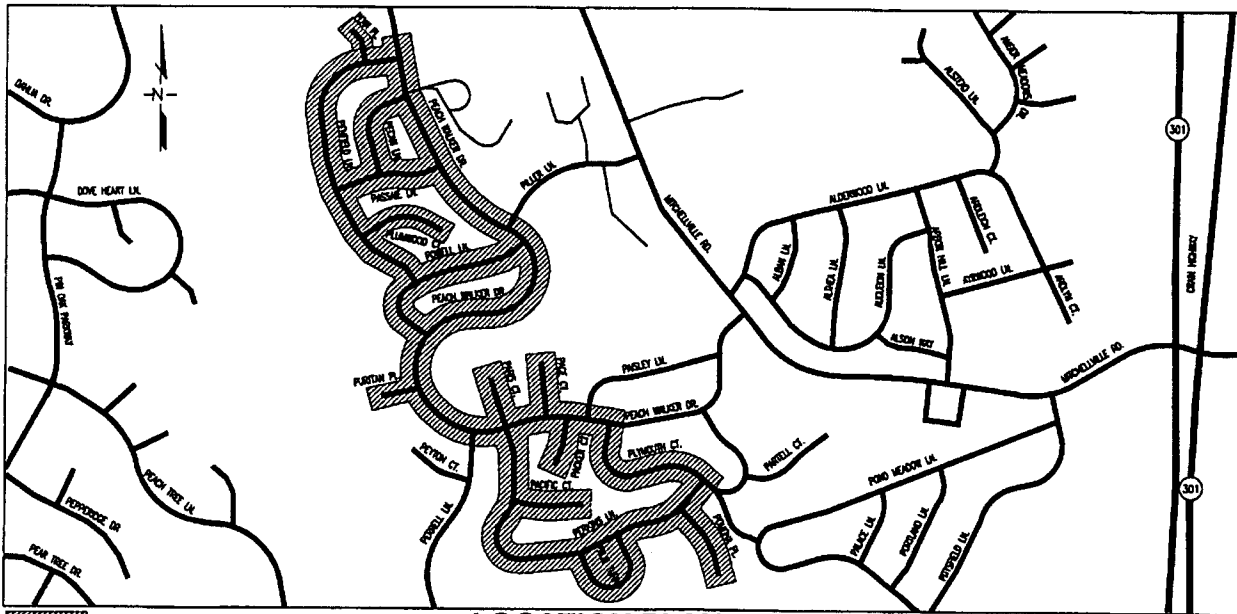

- PEACH WALKER DRIVE
- PENFIELD LANE
- PENN PLACE
- PECAN LANE
- PASSAIE LANE
- PLUMWOOD COURT
- POWELL LANE
- PURITAN PLACE
- PAGE COURT
- PLYMOUTH COURT
- PERKINS LANE
- PACIFIC COURT
- PACKER COURT
- PALAI TURN
- POHONA PLACE
- PILLER LANE
- PERRELL LANE
- PAISLEY LANE

PROJECT AREA

LOCATION PLAN